

MODEL ER14505M

International size reference:UM3/R6/AA



Green Energy
Power Solution Expert

Technical data

- Nominal capacity(at 1 mA +23°C 2V cut off) 2.0Ah
- Rated voltage 3.6V
- Maximum recommended continuous current 400mA
- Maximum pulse current capability 800mA
- Operating temperature range -55°C~+85°C
- Weight Approx 19g
- Storage temperature (recommended) +30°C

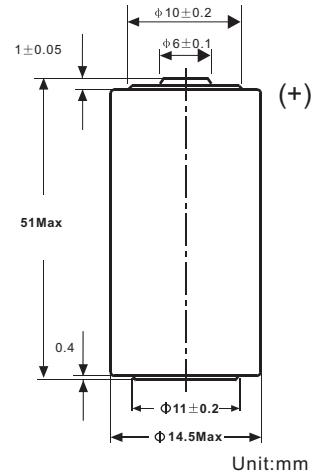

Discharge performance (25°C)

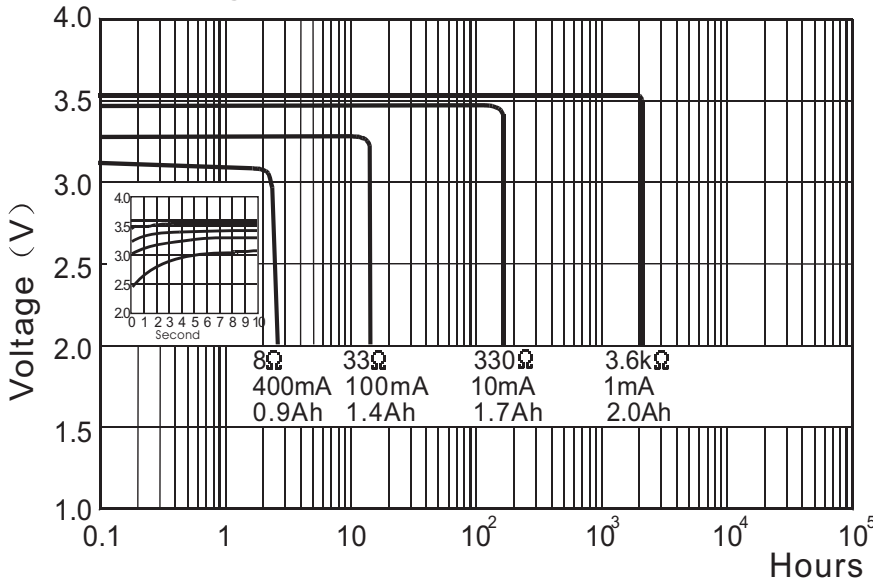

Capacity VS Current

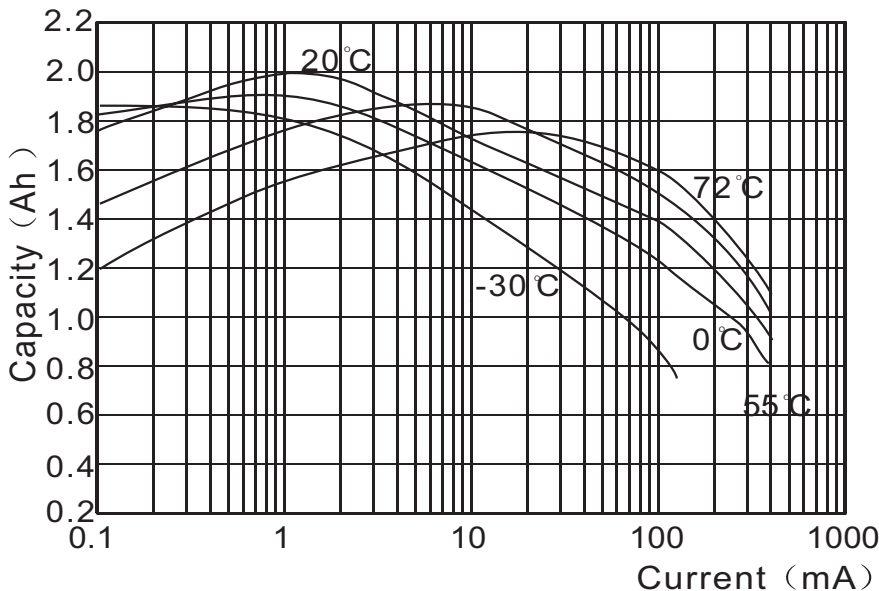

Main applications

- Utility metering
- Automatic meter reading
- Tollgate systems
- Alarms and security devices
- Memory back-up
- Tracking systems
- Automotive electronics
- Professional electronics

Voltage VS Temperature

